



MATHEMATICS METHODS Year 11

Section One: Calculator-free

Student name _____

Teacher name _____

Time and marks available for this section

Reading time before commencing work: 2 minutes
Working time for this section: 15 minutes
Marks available: 15 marks

Materials required/recommended for this section

To be provided by the supervisor

This Question/Answer Booklet
Formula Sheet

To be provided by the candidate

Standard items: pens (blue/black preferred), pencils (including coloured), sharpener,
correction fluid/tape, eraser, ruler, highlighters

Special items: nil

Important note to candidates

No other items may be taken into the examination room. It is **your** responsibility to ensure that you do not have any unauthorised notes or other items of a non-personal nature in the examination room. If you have any unauthorised material with you, hand it to the supervisor **before** reading any further.

Instructions to candidates

1. Write your answers in this Question/Answer Booklet.
2. Answer all questions.
3. **Show all your working clearly.** Your working should be in sufficient detail to allow your answers to be checked readily and for marks to be awarded for reasoning. Incorrect answers given without supporting reasoning cannot be allocated any marks. For any question or part question worth more than two marks, valid working or justification is required to receive full marks. If you repeat an answer to any question, ensure that you cancel the answer you do not wish to have marked.
4. It is recommended that **you do not use pencil**, except in diagrams.

Question 1

(1 mark)

Convert $\frac{5\pi}{9}$ radians to degrees.

$$\frac{5\pi}{9} \times \frac{180}{\pi} = \frac{5\cancel{\pi}}{\cancel{9}} \times \frac{180^{\cancel{20}}}{\cancel{\pi}} = 5 \times 20 = 100^{\circ}$$

Question 2

(2 marks)

The following approximations are true, correct to 2 decimal places:

$$\sin(26^{\circ}) = 0.44 \quad \cos(42^{\circ}) = 0.74$$

Given these approximations, and by considering the unit circle, or otherwise, calculate the values of the following, correct to 2 decimal places:

(a) $\sin(206^{\circ})$.

(1 mark)

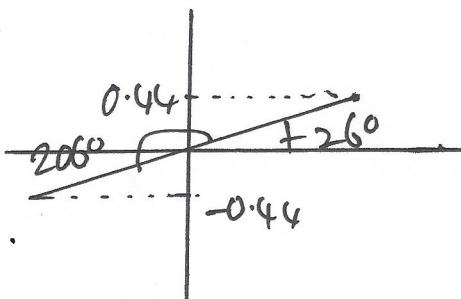

$$\begin{aligned} \sin(206^{\circ}) &= -\sin(26^{\circ}) \\ &= -0.44 \end{aligned}$$

(b) $\cos(318^{\circ})$.

(1 mark)

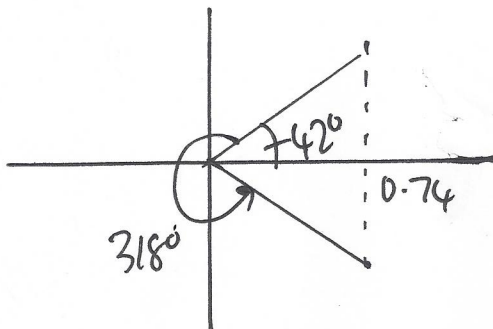

$$\begin{aligned} \cos(318^{\circ}) &= \cos(42^{\circ}) \\ &= 0.74 \end{aligned}$$

Question 3

(5 marks)

Calculate the exact value of x in the following diagram:

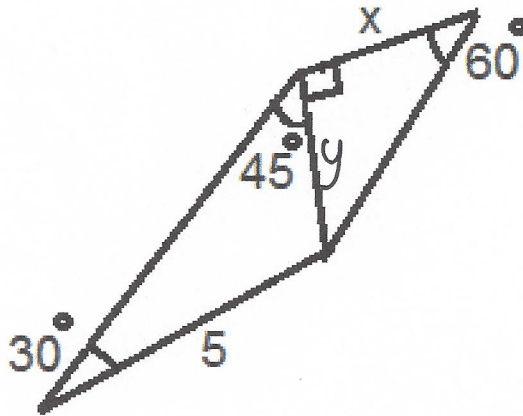
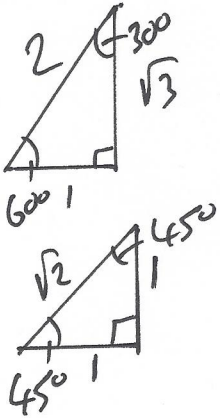

By the Sine Rule $\frac{y}{\sin 30} = \frac{5}{\sin 45}$

$$\frac{y}{1/2} = \frac{5}{1/\sqrt{2}}$$

$$2y = 5\sqrt{2}$$

$$y = \frac{5\sqrt{2}}{2}$$

$$\tan 60 = \sqrt{3} = \frac{5\sqrt{2}/2}{x}$$

$$x = \frac{5\sqrt{2}}{2\sqrt{3}} \quad (\text{or } \frac{5\sqrt{6}}{6} \text{ or similar surd})$$

Question 4

(3 marks)

Consider the straight line on the set of axes below:

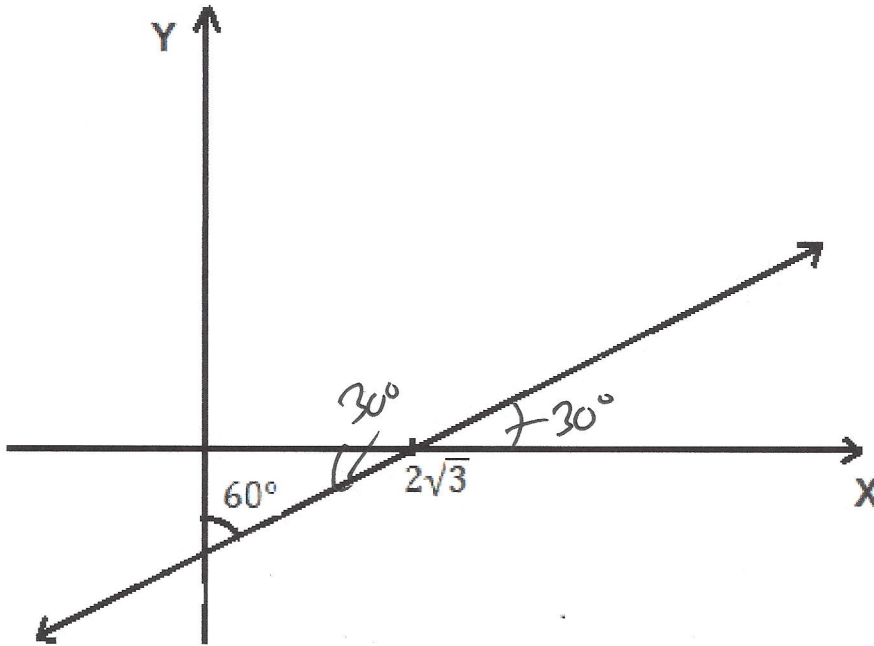

Calculate the following:

(a) The gradient of the line.

(1 mark)

gradient = $\tan 30 = \frac{1}{\sqrt{3}}$ ✓
 (or $\frac{\sqrt{3}}{3}$)

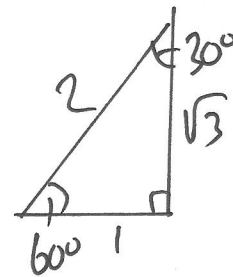

(b) The equation of the line.

(2 marks)

$y = mx + c$
 $y = \frac{1}{\sqrt{3}}x + c$ ✓
 use point $(2\sqrt{3}, 0)$ $0 = \frac{1}{\sqrt{3}} \times 2\sqrt{3} + c$
 $c = -2$
 so $y = \frac{1}{\sqrt{3}}x - 2$ ✓
 (or $y = \frac{\sqrt{3}}{3}x - 2$)

Question 5

(4 marks)

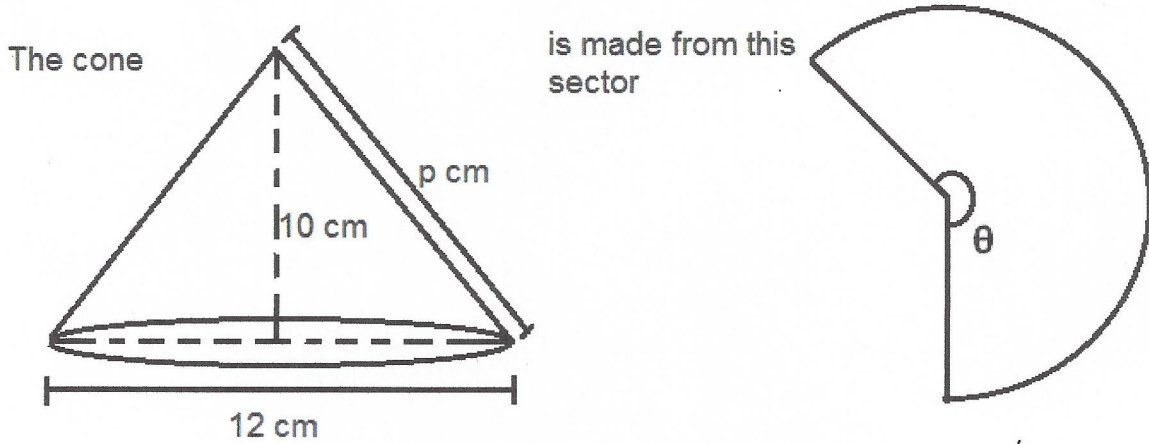

Calculate the following as **exact** values:

- (a) The slant length p centimetres.

(2 marks)

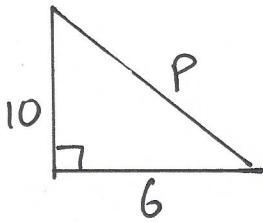

$$\begin{aligned}
 p &= \sqrt{10^2 + 6^2} \\
 &= \sqrt{136} \\
 &= 2\sqrt{34} \text{ cm}
 \end{aligned}$$

} either OK.

- (b) The arc length of the sector.

(1 mark)

$$\text{arc-length} = 2\pi \times 6 = 12\pi \text{ cm}$$

- (c) The sector angle θ in radians.

(1 mark)

$$\begin{aligned}
 \text{arc length} &= r\theta \\
 \theta &= \frac{\text{arc length}}{r} \\
 &= \frac{12\pi}{2\sqrt{34}} = \frac{6\pi}{\sqrt{34}} \text{ radians} \quad \left(\text{or } \frac{3\sqrt{34}\pi}{17} \right. \\
 &\quad \left. \text{or } \frac{12\pi}{\sqrt{136}} \right. \\
 &\quad \left. \text{or } \frac{3\sqrt{136}\pi}{34} \right)
 \end{aligned}$$

End of questions

Additional working space

Question number: _____